

# SPRINGHILL

1453-GL

Marrying organic aesthetics with contemporary design, the raffia panels of Springhill envelop the warm, inviting light within. Curled like leaves around the light source, the tapered shade celebrates the time-honored craft and tactile qualities of the woven raffia. Suspended from a minimalist Gold Leaf chain, Springhill is a sophisticated and fresh accent pendant. Available in two sizes.

\*Due to the one-of-a-kind nature of the medium, exact colors and patterns may vary slightly from the image shown.

## FINISHES

GOLD LEAF

## DIMENSIONS

Height: 66"  
Width/Diameter: 66"  
Length: 66"  
Minimum Height: 66"  
Maximum Height: 66"  
Canopy/Backplate: 5.5"  
Hanging Type: 108" Premium Composite Cord  
Product Weight: 66lb  
Extension: 66"  
Top to Center: 66"  
Canopy/Backplate Shape: Round  
Sloped Ceiling Compatible: No  
Living Finish: Yes  
Uplight Only: Yes

## Shade

Shade 1: Saguran Weave  
Shade 1 Top Width: 8.75"  
Shade 1 Bottom L/W: 0" / 5.5"  
Shade 1 Height: 21.5"

## ELECTRICAL



### Bulb 1

Bulb Included: No  
Socket: E26 Medium Base  
Bulb Type: T10-5.5  
Max Wattage: 15  
Bulb Quantity: 3  
Wire Length: 500mm  
Cord Type: ! New Cord Type  
Dimmer Type: Incandescent  
Switch Type: ON/OFF STOMP SWITCH  
Gem Box Required (2"x3"): Yes  
Dark Sky: Yes  
CRI: 66  
Color Temp.: 66k  
Lumens: 66  
Title 24: Yes  
Field Serviceable: No

### Battery

Battery Powered: Yes  
Battery Included: Yes  
Battery Life: ! New Battery Life !

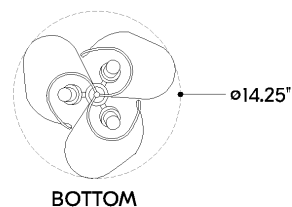
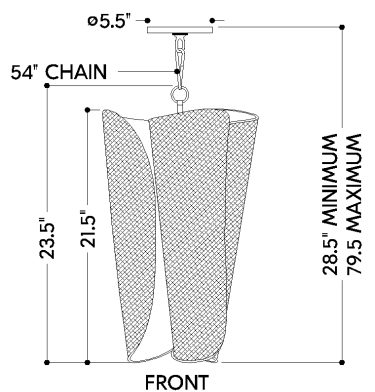

# SPRINGHILL

1453-GL

---

## SHIPPING

---

Carton 1: 28" x 19" x 19"

Carton 1 Weight: 16lb

Shipping Method: Ground

Country of Origin: PH