

SCRANTON

3019-AGB

Inspired by the shape of an apple, Scranton features a softly defined outer layer of etched glass and a narrow 'core' of shiny opal glass within. The freshness of the organic silhouette, paired with the sleek glass layers and metal accents, makes it perfect for a dining room or kitchen. Scranton is available in two sizes and two finishes, Aged Brass and Old Bronze.

FINISHES

AGED BRASS

DIMENSIONS

Height: 66"
Width/Diameter: 66"
Length: 66"
Minimum Height: 66"
Maximum Height: 66"
Canopy/Backplate: 6"
Hanging Type: 108" Premium Composite Cord
Product Weight: 66lb
Extension: 66"
Top to Center: 66"
Canopy/Backplate Shape: Round
Sloped Ceiling Compatible: No
Living Finish: Yes
Uplight Only: Yes

Shade

Shade 1: Glass
Shade 1 Finish: Clear Etched
Shade 1 Top Width: 19"
Shade 1 Height: 16.75"
Shade 2: Glass
Shade 2 Finish: Opal Glossy
Shade 2 Top Width: 4.25"
Shade 2 Height: 15.25"

ELECTRICAL



Bulb 1

Bulb Included: N/A
Socket: Integrated LED
Max Wattage: 28
Bulb Quantity: 1
Wire Length: 500mm
Cord Type: ! New Cord Type
Dimmer Type: Incandescent
Switch Type: ON/OFF STOMP SWITCH
Gem Box Required (2"x3"): Yes
Dark Sky: Yes
CRI: 66
Color Temp.: 66k
Lumens: 66
Title 24: Yes
Field Serviceable: No

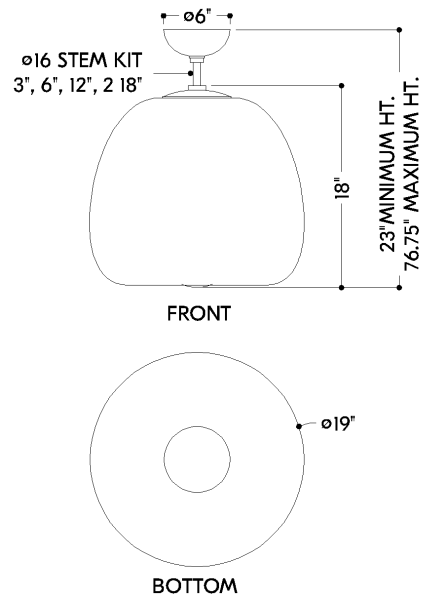

SCRANTON

3019-AGB

Battery

Battery Powered: Yes

Battery Included: Yes

Battery Life: ! New Battery Life !

SHIPPING

Carton 1: 28" x 28" x 22"

Carton 1 Weight: 28lb

Shipping Method: Ground

Country of Origin: CN