

SHILOH

4950-VGL

A dialogue between form and material, this nature-inspired design undulates with charm. The interplay of woven rattan and fluid metalwork creates a dynamic and airy suspension overhead. Accented by a warm Vintage Gold Leaf finish, the detailed craftwork and textural finish present a distinctive, organic look. Illuminated by LED, Shiloh is available in two pendant sizes.

*Due to the one-of-a-kind nature of the medium, exact colors and patterns may vary slightly from the image shown.

FINISHES

VINTAGE GOLD LEAF

DIMENSIONS

Height: 66"
Width/Diameter: 66"
Length: 66"
Minimum Height: 66"
Maximum Height: 66"
Canopy/Backplate: 7"
Hanging Type: 108" Premium Composite Cord
Product Weight: 66lb
Extension: 66"
Top to Center: 66"
Canopy/Backplate Shape: Round
Sloped Ceiling Compatible: No
Living Finish: Yes
Uplight Only: Yes

Shade

Shade 1: Rattan
Shade 1 Finish: Natural
Shade 1 Top Width: 4"
Shade 1 Bottom L/W: 0" / 51.75"
Shade 1 Height: 9"

ELECTRICAL



Bulb 1

Bulb Included: N/A
Socket: Integrated LED
Max Wattage: 40
Bulb Quantity: 1
Wire Length: 500mm
Cord Type: ! New Cord Type
Dimmer Type: Incandescent
Switch Type: ON/OFF STOMP SWITCH
Gem Box Required (2"x3"): Yes
Dark Sky: Yes
CRI: 66
Color Temp.: 66k
Lumens: 66
Title 24: Yes
Field Serviceable: No

Battery

Battery Powered: Yes
Battery Included: Yes
Battery Life: ! New Battery Life !

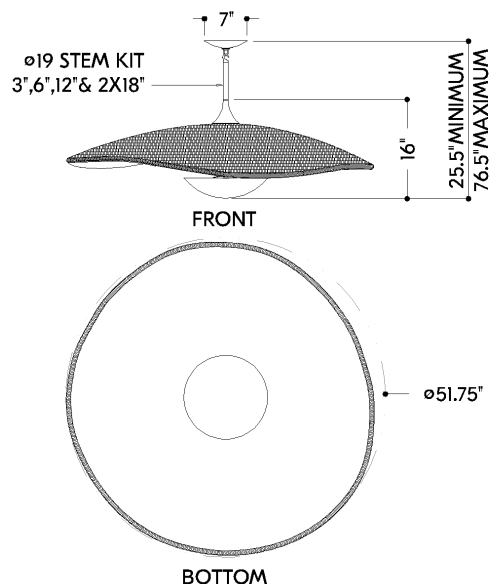

HUDSON VALLEY
LIGHTING GROUP

| hvlgroup.com | 1.800.814.3993

SHILOH

4950-VGL

SHIPPING

Carton 1: 54" x 54" x 18"

Carton 1 Weight: 63lb

Shipping Method: Truck Only

Country of Origin: PH